

Symbol		Dimensions					kg m3 pcs	Composition elements
		W1	W2	D1	D2	H		
<b>LAV96L</b>		920	454			1105	53.9 kg 0.178 m3 5 pcs	LAN8L+LA09L+LAN7P

Extra charge						



Symbol		Dimensions					kg m3 pcs	Composition elements
		W1	W2	D1	D2	H		
<b>LAV95L</b>		920	917			1105	97 kg 0.252 m3 6 pcs	LAN2L+LA09L+LAN1P
<b>LAV75L</b>		1366	917			1105	114.95 kg 0.326 m3 6 pcs	LAN2L+LA13L+LAN1P
<b>LAV76L</b>		1666	917			1105	128.85 kg 0.373 m3 6 pcs	LAN2L+LA16L+LAN1P
<b>LAV77L</b>		2366	917			1105	155.9 kg 0.497 m3 7 pcs	LAN2L+LA23L+LAN1P

Extra charge						
<b>Monitor shelf x1</b>						
X						
X						
X						

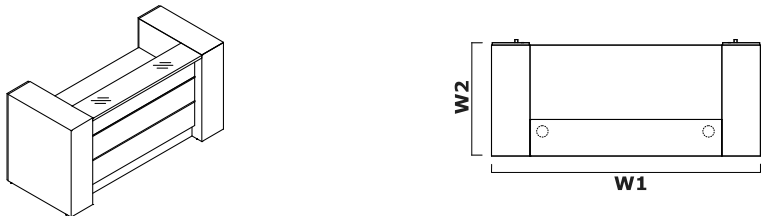

Symbol		Dimensions					kg m3 pcs	Composition elements
		W1	W2	D1	D2	H		
LAV01L		1926	937			1105	167.55 kg 0.973 m3 8 pcs	LAD10+LAL10+LA13L+LAP10 +LAD10
LAV02L		2226	937			1105	181.45 kg 1.02 m3 8 pcs	LAD10+LAL10+LA16L+LAP10 +LAD10
LAV03L		2926	937			1105	208.5 kg 1.145 m3 9 pcs	LAD10+LAL10+LA23L+LAP10 +LAD10

Extra charge						
Monitor shelf x1						
X						
X						
X						



Symbol		Dimensions					kg m3 pcs	Composition elements
		W1	W2	D1	D2	H		
LAV10L		1908	1908	991	991	1105	238.65 kg 1.374 m3 14 pcs	LAD10+LAL10+LAL13L+LA100+LAP13L+LAP10+LAD10+NL41
LAV11L		1908	2208	991	1291	1105	251.95 kg 1.421 m3 14 pcs	LAD10+LAL10+LAL13L+LA100+LAP16L+LAP10+LAD10+NL41
LAV12L		1908	2908	991	1991	1105	279.05 kg 1.546 m3 15 pcs	LAD10+LAL10+LAL13L+LA100+LAP23L+LAP10+LAD10+NL41
LAV13L		2208	1908	1291	991	1105	252.4 kg 1.421 m3 14 pcs	LAD10+LAL10+LAL16L+LA100+LAP13L+LAP10+LAD10+NL41
LAV14L		2208	2208	1291	1291	1105	265.7 kg 1.468 m3 14 pcs	LAD10+LAL10+LAL16L+LA100+LAP16L+LAP10+LAD10+NL41
LAV15L		2208	2908	1291	1991	1105	292.8 kg 1.593 m3 15 pcs	LAD10+LAL10+LAL16L+LA100+LAP23L+LAP10+LAD10+NL41

Extra charge						
Monitor shelf x1	Monitor shelf x 2					
X	X					
X	X					
X	X					
X	X					
X	X					



Symbol		Dimensions					kg m3 pcs	Composition elements
		W1	W2	D1	D2	H		
LAV16L		2908	1908	1991	991	1105	279.55 kg 1.546 m3 15 pcs	LAD10+LAL10+LAL23L+LA100 +LAP13L+LAP10+LAD10+NL41
LAV17L		2908	2208	1991	1291	1105	292.85 kg 1.593 m3 15 pcs	LAD10+LAL10+LAL23L+LA100 +LAP16L+LAP10+LAD10+NL41
LAV18L		2908	2908	1991	1991	1105	319.95 kg 1.717 m3 16 pcs	LAD10+LAL10+LAL23L+LA100 +LAP23L+LAP10+LAD10+NL41

Extra charge						
Monitor shelf x1	Monitor shelf x 2					
X	X					
X	X					
X	X					

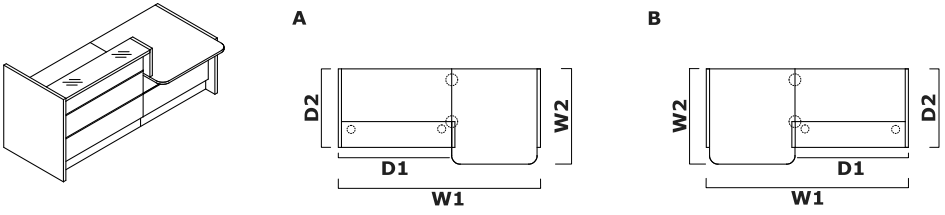

Symbol			Dimensions					kg m3 pcs	Composition elements
A	B		W1	W2	D1	D2	H		
LAV19L	LAV20L		2366	1114	1328	917	1105	152.3 kg 0.509 m3 12 pcs	A - LAN6L+LAU11L+LAN4L+LA13L+LAN1P+NL41 B - LAN2L+LA13L+LAN3P+LAU11L +LAN5P+NL41
LAV21L	LAV22L		2666	1114	1628	917	1105	166.2 kg 0.556 m3 12 pcs	A - LAN6L+LAU11L+LAN4L+LA16L+LAN1P+NL41 B - LAN2L+LA16L+LAN3P+LAU11L +LAN5P+NL41
LAV23L	LAV24L		3366	1114	2318	917	1105	193.25 kg 0.68 m3 13 pcs	A - LAN6L+LAU11L+LAN4L+LA23L+LAN1P+NL41 B - LAN2L+LA23L+LAN3P+LAU11L +LAN5P+NL41
LAV191L	LAV201L		2166	1114	1328	917	1105	145.05 kg 0.486 m3 12 pcs	A - LAN6L+LAU18L+LAN4L+LA13L +LAN1P+NL41 B - LAN2L+LA13L+LAN3P+LAU18L +LAN5P+NL41
LAV211L	LAV221L		2466	1114	1628	917	1105	158.95 kg 0.533 m3 12 pcs	A - LAN6L+LAU18L+LAN4L+LA16L +LAN1P+NL41 B - LAN2L+LA16L+LAN3P+LAU18L +LAN5P+NL41
LAV231L	LAV241L		3166	1114	2318	917	1105	186 kg 0.657 m3 13 pcs	A - LAN6L+LAU18L+LAN4L+LA23L +LAN1P+NL41 B - LAN2L+LA23L+LAN3P+LAU18L +LAN5P+NL41

Extra charge						
Monitor shelf x1						
X						
X						
X						
X						
X						
X						

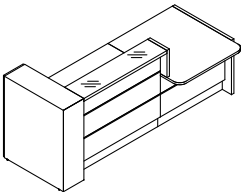

**A**

**B**

Symbol		Dimensions	kg m3 pcs	Composition elements				
A	B				W1	W2	D1	D2
LAV41L	LAV42L	2646	1134	1608	937	1105	178.4 kg 0.833 m3 13 pcs	A - LAN6L+LAU11L+LAN4L+LA13L+LAP10+LAD10+NL41 B - LAD10+LAL10+LA13L+LAN3P +LAU11L+LAN5P+NL41
LAV43L	LAV44L	2946	1134	1908	937	1105	192.3 kg 0.88 m3 13 pcs	A - LAN6L+LAU11L+LAN4L+LA16L+LAP10+LAD10+NL41 B - LAD10+LAL10+LA16L+LAN3P +LAU11L+LAN5P+NL41
LAV45L	LAV46L	3646	1134	2608	937	1105	219.35 kg 1.004 m3 14 pcs	A - LAN6L+LAU11L+LAN4L+LA23L+LAP10+LAD10+NL41 B - LAD10+LAL10+LA23L+LAN3P +LAU11L+LAN5P+NL41
LAV411L	LAV421L	2446	1134	1608	937	1105	171.15 kg 0.809 m3 13 pcs	A - LAN6L+LAU18L+LAN4L+LA13L +LAP10+LAD10+NL41 B - LAD10+LAL10+LA13L+LAN3P +LAU18L+LAN5P+NL41
LAV431L	LAV441L	2746	1134	1908	937	1105	185.05 kg 0.856 m3 13 pcs	A - LAN6L+LAU18L+LAN4L+LA16L +LAP10+LAD10+NL41 B - LAD10+LAL10+LA16L+LAN3P +LAU18L+LAN5P+NL41
LAV451L	LAV461L	3446	1134	2608	937	1105	212.1 kg 0.981 m3 14 pcs	A - LAN6L+LAU18L+LAN4L+LA23L +LAP10+LAD10+NL41 B - LAD10+LAL10+LA23L+LAN3P +LAU18L+LAN5P+NL41

Extra charge						
Monitor shelf x1						
X						
X						
X						
X						
X						
X						

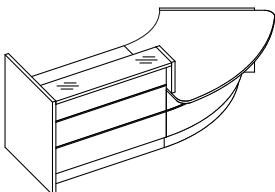

**A**

**B**

Symbol		Dimensions	kg m3 pcs	Composition elements				
A	B				W1	W2	D1	D2
LAV88L	LAV89L	2845	1486	1328	917	1105	164.2 kg 0.832 m3 12 pcs	A - LAN6L+LAV66L+LAN4L+LA13L+LAN1P+NL41 B - LAN2L+LA13L+LAN3P+LAV66L+LAN5P+NL41
LAV91L	LAV92L	3145	1486	1628	917	1105	178.1 kg 0.879 m3 12 pcs	A - LAN6L+LAV66L+LAN4L+LA16L+LAN1P+NL41 B - LAN2L+LA16L+LAN3P+LAV66L+LAN5P+NL41

Extra charge						
Monitor shelf x1						
X						
X						

Symbol		Dimensions					kg m3 pcs	Composition elements
A	B	W1	W2	D1	D2	H		
LAV93L	LAV94L	3845	1486	2318	917	1105	205.15 kg 1.003 m3 13 pcs	A - LAN6L+LAV66L+LAN4L+LA23L+LAN1P+NL41 B - LAN2L+LA23L+LAN3P+LAV66L+LAN5P+NL41

Extra charge						
Monitor shelf x1						
X						

Symbol		Dimensions					kg m3 pcs	Composition elements
A	B	W1	W2	D1	D2	H		
LAV84L	LAV85L	2443	1489	1404	1114	1105	157.5 kg 0.957 m3 12 pcs	A - LAN2L+LAV64L+LAN3P+LAU11L +LAN5P+NL41 B - LAN6L+LAU11L+LAN4L+LAV64L +LAN1P+NL41
LAV841L	LAV851L	2243	1489	1404	1114	1105	150.25 kg 0.934 m3 12 pcs	A - LAN2L+LAV64L+LAN3P+LAU18L+LAN5P+NL41 B - LAN6L+LAU18L+LAN4L+LAV64L+LAN1P+NL41

Extra charge						
Monitor shelf x1						
X						
X						

Symbol		Dimensions					kg m3 pcs	Composition elements
A	B	W1	W2	D1	D2	H		
LAV86L	LAV87L	2638	1835	1600	937	1105	203.9 kg 1.328 m3 13 pcs	A - LAN2L+LAV90L+LAN3P+LAU11L +LAN5P+NL41 B - LAN6L+LAU11L+LAN4L+LAV90L +LAN1P+NL41
LAV861L	LAV871L	2438	1835	1600	937	1105	196.65 kg 1.305 m3 13 pcs	A - LAN2L+LAV90L+LAN3P+LAU18L+LAN5P+NL41 B - LAN6L+LAU18L+LAN4L+LAV90L+LAN1P+NL41

Extra charge						
Monitor shelf x1						
X						
X						

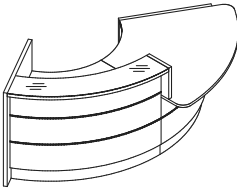

**A**

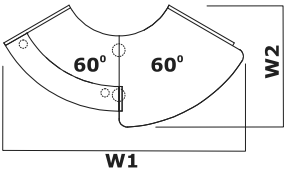

**B**

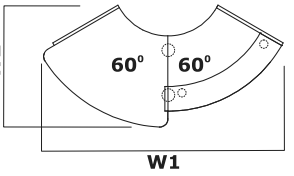

Symbol		Dimensions	kg m3 pcs	Composition elements
A	B			
<b>LAV30L</b>	<b>LAV31L</b>	W1: 2922, W2: 1486, H: 1105	169.9 kg 1.28 m3 12 pcs	A - LAN6L+LAV66L+LAN4L+LAV64L +LAN1P+NL41 B - LAN2L+LAV64L+LAN3P+LAV66L +LAN5P+NL41

Extra charge						
Monitor shelf x1						
X						

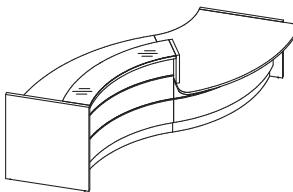

**A**

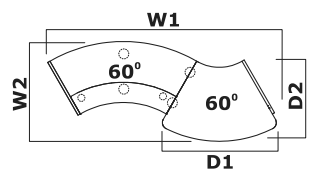

**B**

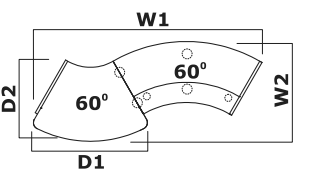

Symbol		Dimensions	kg m3 pcs	Composition elements
A	B			
<b>LAV32L</b>	<b>LAV33L</b>	W1: 3452, W2: 1502, D1: 1720, D2: 1225, H: 1105	183.5 kg 1.366 m3 13 pcs	A - LAN6L+LAV66L+LAN4L+LAV62L +LAN1P+NL41 B - LAN2L+LAV62L+LAN3P+LAV66L +LAN5P+NL41

Extra charge						
Monitor shelf x1						
X						

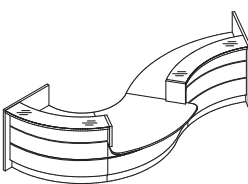

**A**

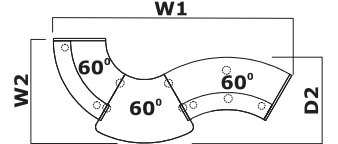

**B**

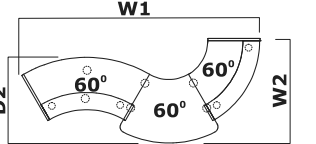

Symbol		Dimensions	kg m3 pcs	Composition elements
A	B			
<b>LAV34L</b>	<b>LAV35L</b>	W1: 4195, W2: 1835, D2: 1503, H: 1105	262.75 kg 2.129 m3 20 pcs	A - LAN2L+LAV62L+LAN3P+LAV66L +LAN4L+LAV64L+LAN1P+2xNL41 B - LAN2L+LAV64L+LAN3P+LAV66L +LAN4L+LAV62L+LAN1P+2xNL41

Extra charge						
Monitor shelf x1	Monitor shelf x 2					
X	X					

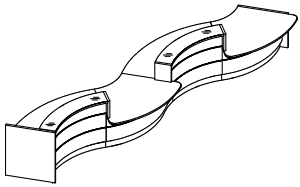

**A**

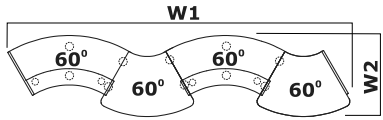

**B**

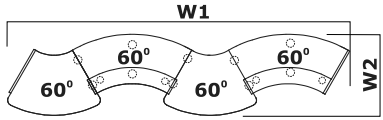

Symbol		Dimensions					kg m3 pcs	Composition elements
A	B	W1	W2	D1	D2	H		
<b>LAV36L</b>	<b>LAV37L</b>	6352	1503			1105	322.6 kg 2.715 m3 26 pcs	A - LAN6L+2xLAV66L+2xLAN4L+2xLAV62L+LAN3P+LAN1P +3xNL41 B - LAN2L+2xLAV62L+2xLAN3P+2xLAV66L+LAN4L+LAN5P +3xNL41

Extra charge					
Monitor shelf x1	Monitor shelf x 2				
X	X				

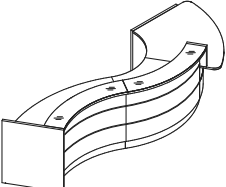

**A**

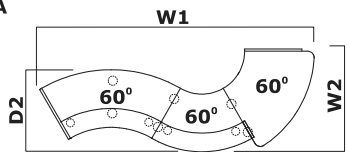

**B**

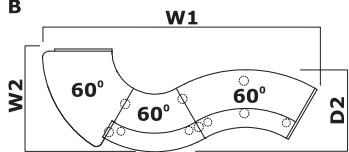

Symbol		Dimensions					kg m3 pcs	Composition elements
A	B	W1	W2	D1	D2	H		
<b>LAV38L</b>	<b>LAV39L</b>	4386	1639		1307	1105	249.75 kg 2.106 m3 19 pcs	A - LAN6L+LAV66L+LAN4L+LAV64L +LAV62L+LAN1P+2xNL41 B - LAN2L+LAV62L+LAV64L+LAN3P +LAV66L+LAN5P+2xNL41

Extra charge					
Monitor shelf x1	Monitor shelf x 2				
X	X				

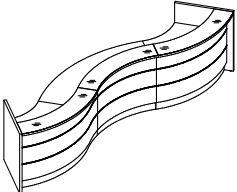

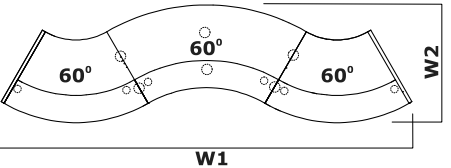

Symbol		Dimensions					kg m3 pcs	Composition elements
		W1	W2	D1	D2	H		
<b>LAV50L</b>		4566	1307			1105	260.15 kg 2.329 m3 17 pcs	LAN2L+2xLAV64L+LAV62L+LAN1P+2xNL41

Extra charge					
Monitor shelf x1	Monitor shelf x 2	Monitor shelf x 3			
X	X	X			

Symbol		Dimensions					kg m3 pcs	Composition elements
		W1	W2	D1	D2	H		
<b>LAV51L</b>		3202	3006			1105	415.2 kg 3.741 m3 27 pcs	LAN2L+2xLAV64L+2xLAV90L +LAN1P+3xNL41

Extra charge						
Monitor shelf x1	Monitor shelf x 2	Monitor shelf x 3	Monitor shelf x 4			
X	X	X	X			

Symbol		Dimensions					kg m3 pcs	Composition elements
		W1	W2	D1	D2	H		
<b>LAV52L</b>		3202	1639			1105	282.7 kg 2.261 m3 15 pcs	LAN2L+2xLAV90L+LAN1P+NL41

Extra charge						
Monitor shelf x1	Monitor shelf x 2					
X	X					

Symbol		Dimensions					kg m3 pcs	Composition elements
		W1	W2	D1	D2	H		
<b>LAV61L</b>		3202	1919			1105	329.5 kg 2.898 m3 15 pcs	LAD10+LAL10+2xLAV90L+LAP10+LAD10+NL41

Extra charge						
Monitor shelf x1	Monitor shelf x 2					
X	X					



Symbol	Dimensions	kg	m3	pcs	Composition elements		
						W1	W2
<b>LAV04L</b>	3202 3006				1105	239 kg 2.312 m3 23 pcs	LAN8L+2xLAV70L+2xLAV64L +LAN7P+3xNL41

Extra charge						
Monitor shelf x1	Monitor shelf x 2					
X	X					

Symbol	Dimensions	kg	m3	pcs	Composition elements		
						W1	W2
<b>LAV53L</b>	2317 1145				1105	170.05 kg 1.15 m3 8 pcs	LAN2L+LAV90L+LAN1P

Extra charge						
Monitor shelf x1						
X						

Symbol	Dimensions	kg	m3	pcs	Composition elements		
						W1	W2
<b>LAV73L</b>	2713 1353				1105	222.65 kg 1.798 m3 10 pcs	LAD10+LAL10+LAV90L+LAP10+LAD10

Extra charge						
Monitor shelf x1						
X						

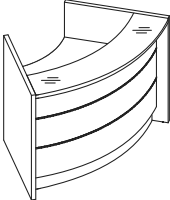
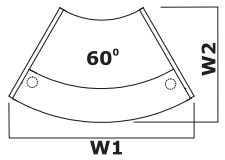
Symbol	Dimensions					kg m3 pcs	Composition elements
	W1	W2	D1	D2	H		
<b>LAV54L</b>	1666	1029			1105	123.65 kg 0.779 m3 7 pcs	LAN2L+LAV64L+LAN1P

Extra charge						
Monitor shelf x1						
X						

Symbol	Dimensions					kg m3 pcs	Composition elements
	W1	W2	D1	D2	H		
<b>LAV74L</b>	2151	1183			1105	176.25 kg 1.427 m3 9 pcs	LAD10+LAL10+LAV64L+LAP10+LAD10

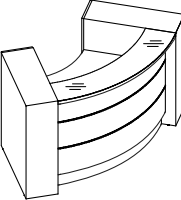
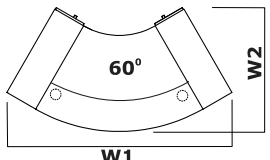
Extra charge						
Monitor shelf x1						
X						

Symbol		Dimensions					kg m3 pcs	Composition elements
A	B	W1	W2	D1	D2	H		
<b>LAV78L</b>	<b>LAV79L</b>	2733	1292	1328	917	1105	184.2 kg 1.071 m3 13 pcs	A - LAN2L+LAV64L+LA13L+LAN1P+NL41 B - LAN2L+LA13L+LAV64L+LAN1P+NL41
<b>LAV80L</b>	<b>LAV81L</b>	3033	1292	1628	917	1105	198.1 kg 1.118 m3 13 pcs	A - LAN2L+LAV64L+LA16L+LAN1P+NL41 B - LAN2L+LA16L+LAV64L+LAN1P+NL41
<b>LAV82L</b>	<b>LAV83L</b>	3733	1292	2318	917	1105	225.15 kg 1.242 m3 14 pcs	A - LAN2L+LAV64L+LA23L+LAN1P+NL41 B - LAN2L+LA23L+LAV64L+LAN1P+NL41

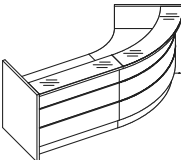
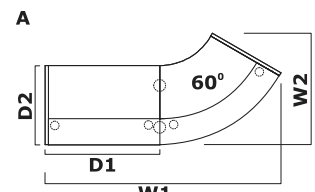
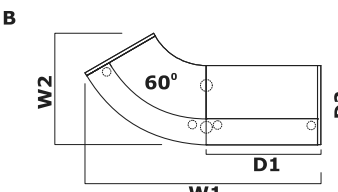
Extra charge						
Monitor shelf x1	Monitor shelf x 2					
X	X					
X	X					
X	X					

Symbol		Dimensions					kg m3 pcs	Composition elements
A	B	W1	W2	D1	D2	H		
LAV55L	LAV56L	3208	1918	1608	937	1105	283.2 kg 2.089 m3 16 pcs	A - LAD10+LAL10+LAV90L+LA13L+LAP10+LAD10+NL41 B - LAD10+LAL10+LA13L+LAV90L+LAP10+LAD10+NL41
LAV57L	LAV58L	3508	1918	1908	937	1105	297.1 kg 2.137 m3 16 pcs	A - LAD10+LAL10+LAV90L+LA16L+LAP10+LAD10+NL41 B - LAD10+LAL10+LA16L+LAV90L+LAP10+LAD10+NL41

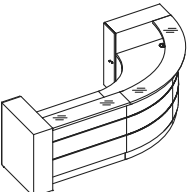
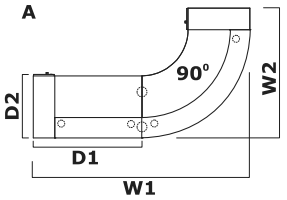
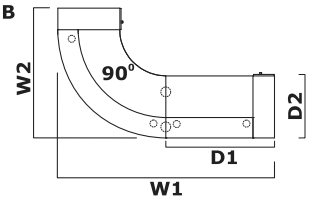
Extra charge					
Monitor shelf x1	Monitor shelf x 2				
X	X				
X	X				

Symbol		Dimensions					kg m3 pcs	Composition elements
A	B	W1	W2	D1	D2	H		
LAV59L	LAV60L	4208	1918	2608	937	1105	324.15 kg 2.261 m3 17 pcs	A - LAD10+LAL10+LAV90L+LA23L+LAP10+LAD10+NL41 B - LAD10+LAL10+LA23L+LAV90L+LAP10+LAD10+NL41

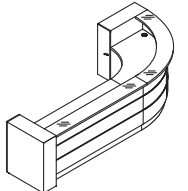
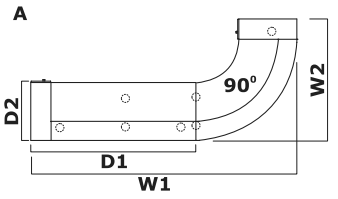
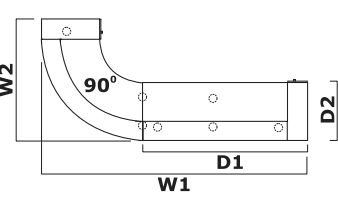
Extra charge					
Monitor shelf x1	Monitor shelf x 2				
X	X				

Symbol		Dimensions					kg m3 pcs	Composition elements
		W1	W2	D1	D2	H		
LAV107L		3437	2437	2318	1328	1105	256.55 kg 1.121 m3 18 pcs	LAN2L+LA13L+LAN3P+LAV68L+LAN4L+LA23L+LAN1P+2xNL41
LAV108L		3437	2737	2318	1628	1105	270.45 kg 1.168 m3 18 pcs	LAN2L+LA16L+LAN3P+LAV68L+LAN4L+LA23L+LAN1P+2xNL41
LAV109L		3437	3437	2318	2318	1105	297.5 kg 1.293 m3 19 pcs	LAN2L+LA23L+LAN3P+LAV68L+LAN4L+LA23L+LAN1P+2xNL41

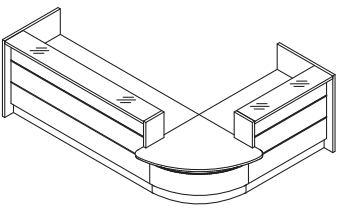
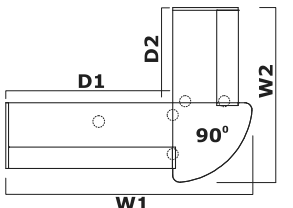
Extra charge					
Monitor shelf x1	Monitor shelf x 2				
X	X				
X	X				
X	X				

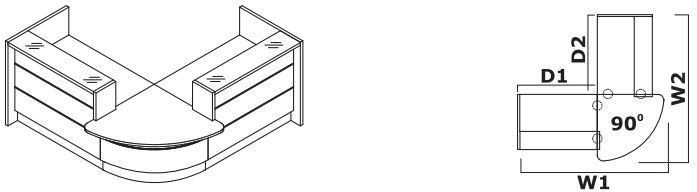

Symbol		Dimensions					kg m3 pcs	Composition elements
		W1	W2	D1	D2	H		
LAV101L		2437	2437	1328	1328	1105	215.6 kg 0.95 m3 17 pcs	LAN2L+LA13L+LAN3P+LAV68L+LAN4L+LA13L+LAN1P+2xNL41
LAV102L		2437	2737	1328	1628	1105	229.5 kg 0.997 m3 17 pcs	LAN2L+LA16L+LAN3P+LAV68L+LAN4L+LA13L+LAN1P+2xNL41
LAV103L		2437	3437	1328	2318	1105	256.55 kg 1.121 m3 18 pcs	LAN2L+LA23L+LAN3P+LAV68L+LAN4L+LA13L+LAN1P+2xNL41
LAV104L		2737	2437	1628	1328	1105	229.5 kg 0.997 m3 17 pcs	LAN2L+LA13L+LAN3P+LAV68L+LAN4L+LA16L+LAN1P+2xNL41
LAV105L		2737	2737	1628	1628	1105	243.4 kg 1.044 m3 17 pcs	LAN2L+LA16L+LAN3P+LAV68L+LAN4L+LA16L+LAN1P+2xNL41
LAV106L		2737	3437	1628	2318	1105	270.45 kg 1.168 m3 18 pcs	LAN2L+LA23L+LAN3P+LAV68L+LAN4L+LA16L+LAN1P+2xNL41

Extra charge						
Monitor shelf x1	Monitor shelf x 2					
X	X					
X	X					
X	X					
X	X					
X	X					
X	X					

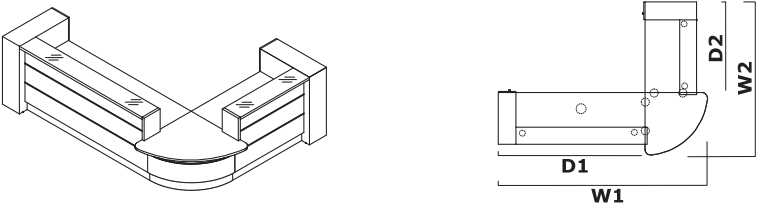

Symbol		Dimensions					kg m3 pcs	Composition elements
		W1	W2	D1	D2	H		
LAV122L		3717	2717	2608	1608	1105	309.15 kg 1.769 m3 20 pcs	LAD10+LAL10+LA13L+LAN3P +LAV68L+LAN4L+LA23L+LAP10 +LAD10+2xNL41
LAV123L		3717	3017	2608	1908	1105	323.05 kg 1.816 m3 20 pcs	LAD10+LAL10+LA16L+LAN3P +LAV68L+LAN4L+LA23L+LAP10 +LAD10+2xNL41
LAV124L		3717	3717	2608	2608	1105	350.1 kg 1.94 m3 21 pcs	LAD10+LAL10+LA23L+LAN3P +LAV68L+LAN4L+LA23L+LAP10 +LAD10+2xNL41

Extra charge						
Monitor shelf x1	Monitor shelf x 2					
X	X					
X	X					
X	X					

Symbol		Dimensions	kg m3 pcs	Composition elements				
A	B				W1	W2	D1	D2
LAV110L	LAV111L	2442	2147	1328	917	1105	187.3 kg 0.832 m3 16 pcs	A - LAN2L+LA13L+LAN3P+LAV68L+LAU11L+LAN5P+2xNL41 B - LAN6L+LAU11L+LAV68L+LAN4L +LA13L+LAN1P+2xNL41
LAV112L	LAV113L	2742	2147	1628	917	1105	201.2 kg 0.879 m3 16 pcs	A - LAN2L+LA16L+LAN3P+LAV68L+LAU11L+LAN5P+2xNL41 B - LAN6L+LAU11L+LAV68L+LAN4L +LA16L+LAN1P+2xNL41
LAV114L	LAV115L	3442	2147	2318	917	1105	228.25 kg 1.004 m3 17 pcs	A - LAN2L+LA23L+LAN3P+LAV68L+LAU11L+LAN5P+2xNL41 B - LAN6L+LAU11L+LAV68L+LAN4L +LA23L+LAN1P+2xNL41
LAV1101L	LAV1111L	2442	1947	1328	917	1105	180.05 kg 0.809 m3 16 pcs	A - LAN2L+LA13L+LAN3P+LAV68L+LAU18L+LAN5P+2xNL41 B - LAN6L+LAU18L+LAV68L+LAN4L+LA13L+LAN1P+2xNL41
LAV1121L	LAV1131L	2742	1947	1628	917	1105	193.95 kg 0.856 m3 16 pcs	A - LAN2L+LA16L+LAN3P+LAV68L+LAU18L+LAN5P+2xNL41 B - LAN6L+LAU18L+LAV68L+LAN4L+LA16L+LAN1P+2xNL41
LAV1141L	LAV1151L	3442	1947	2318	917	1105	221 kg 0.98 m3 17 pcs	A - LAN2L+LA23L+LAN3P+LAV68L+LAU18L+LAN5P+2xNL41 B - LAN6L+LAU18L+LAV68L+LAN4L+LA23L+LAN1P+2xNL41

Extra charge					
Monitor shelf x1					
X					
X					
X					
X					
X					
X					

Symbol		Dimensions	kg m3 pcs	Composition elements				
					W1	W2	D1	D2
LAV116L		2717	2717	1608	1608	1105	268.2 kg 1.597 m3 19 pcs	LAD10+LAL10+LA13L+LAN3P +LAV68L+LAN4L+LA13L+LAP10 +LAD10+2xNL41
LAV117L		2717	3017	1608	1908	1105	282.1 kg 1.644 m3 19 pcs	LAD10+LAL10+LA16L+LAN3P +LAV68L+LAN4L+LA13L+LAP10 +LAD10+2xNL41
LAV118L		2717	3717	1608	2608	1105	309.15 kg 1.769 m3 20 pcs	LAD10+LAL10+LA23L+LAN3P +LAV68L+LAN4L+LA13L+LAP10 +LAD10+2xNL41
LAV119L		3017	2717	1908	1608	1105	282.1 kg 1.644 m3 19 pcs	LAD10+LAL10+LA13L+LAN3P +LAV68L+LAN4L+LA16L+LAP10 +LAD10+2xNL41

Extra charge					
Monitor shelf x1	Monitor shelf x 2				
X	X				
X	X				
X	X				
X	X				

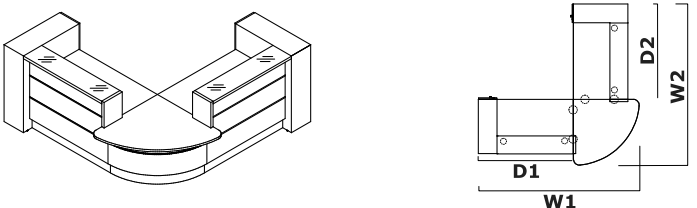

Symbol		Dimensions					kg m3 pcs	Composition elements
		W1	W2	D1	D2	H		
<b>LAV120L</b>		3017	3017	1908	1908	1105	296 kg 1.691 m3 19 pcs	LAD10+LAL10+LA16L+LAN3P +LAV68L+LAN4L+LA16L+LAP10 +LAD10+2xNL41
<b>LAV121L</b>		3017	3717	1908	2608	1105	323.05 kg 1.816 m3 20 pcs	LAD10+LAL10+LA23L+LAN3P +LAV68L+LAN4L+LA16L+LAP10 +LAD10+2xNL41

Extra charge					
Monitor shelf x1	Monitor shelf x 2				
X	X				
X	X				

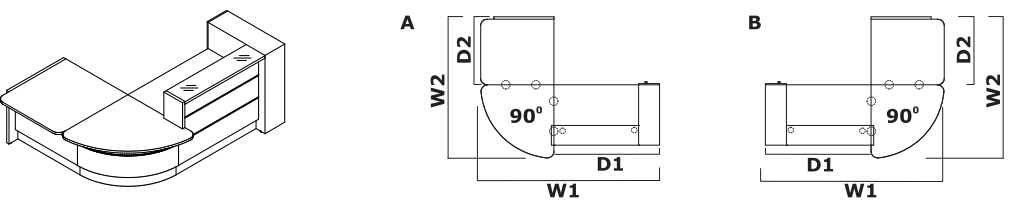

Symbol		Dimensions					kg m3 pcs	Composition elements
		W1	W2	D1	D2	H		
<b>LAV125L</b>	<b>LAV126L</b>	2722	2147	1608	1038	1105	216.8 kg 1.162 m3 17 pcs	A - LAD10+LAL10+LA13L+LAN3P +LAV68L+LAU11L+LAN5P+2xNL41 B - LAN6L+LAU11L+LAV68L+LAN4L +LA13L+LAP10+LAD10+2xNL41
<b>LAV127L</b>	<b>LAV128L</b>	3022	2147	1908	1038	1105	224.7 kg 1.198 m3 16 pcs	A - LAD10+LAL10+LA16L+LAN3P +LAV68L+LAU11L+LAN5P+2xNL41 B - LAN6L+LAU11L+LAV68L+LAN4L +LA16L+LAP10+LAD10+2xNL41
<b>LAV129L</b>	<b>LAV130L</b>	3722	2147	2608	1038	1105	251.75 kg 1.322 m3 17 pcs	A - LAD10+LAL10+LA23L+LAN3P +LAV68L+LAU11L+LAN5P+2xNL41 B - LAN6L+LAU11L+LAV68L+LAN4L +LA23L+LAP10+LAD10+2xNL41
<b>LAV1251L</b>	<b>LAV1261L</b>	2722	1947	1608	838	1105	209.55 kg 1.138 m3 17 pcs	A - LAD10+LAL10+LA13L+LAN3P +LAV68L+LAU18L+LAN5P+2xNL41 B - LAN6L+LAU18L+LAV68L+LAN4L+LA13L+LAP10+LAD10+2xNL41
<b>LAV1271L</b>	<b>LAV1281L</b>	3022	1947	1908	838	1105	217.45 kg 1.175 m3 16 pcs	A - LAD10+LAL10+LA16L+LAN3P+LAV68L+LAU18L+LAN5P+2xNL41 B - LAN6L+LAU18L+LAV68L+LAN4L+LA16L+LAP10+LAD10+2xNL41
<b>LAV1291L</b>	<b>LAV1301L</b>	3722	1947	2608	838	1105	244.5 kg 1.299 m3 17 pcs	A - LAD10+LAL10+LA23L+LAN3P +LAV68L+LAU18L+LAN5P+2xNL41 B - LAN6L+LAU18L+LAV68L+LAN4L+LA23L+LAP10+LAD10+2xNL41

Extra charge					
Monitor shelf x1					
X					
X					
X					
X					
X					
X					

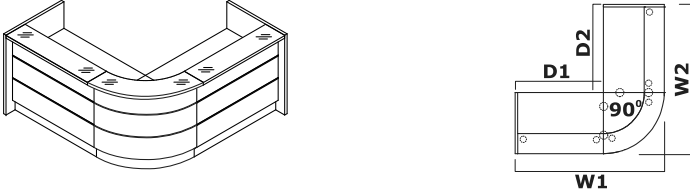

Symbol		Dimensions					kg m3 pcs	Composition elements
		W1	W2	D1	D2	H		
<b>LAV131L</b>		2245	2245	1328	1328	1105	214 kg 1.036 m3 16 pcs	LAN2L+LA13L+LAV70L+LA13L+LAN1P+2xNL41
<b>LAV132L</b>		2245	2545	1328	1628	1105	227.9 kg 1.083 m3 16 pcs	LAN2L+LA16L+LAV70L+LA13L+LAN1P+2xNL41
<b>LAV133L</b>		2245	3245	1328	2318	1105	254.95 kg 1.208 m3 17 pcs	LAN2L+LA23L+LAV70L+LA13L+LAN1P+2xNL41

Extra charge						
Monitor shelf x1	Monitor shelf x 2					
X	X					
X	X					
X	X					

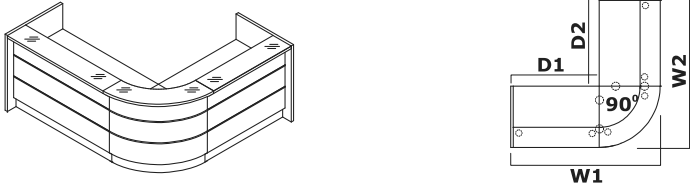

Symbol		Dimensions					kg m3 pcs	Composition elements
		W1	W2	D1	D2	H		
<b>LAV134L</b>		2545	2245	1628	1328	1105	227.9 kg 1.083 m3 16 pcs	LAN2L+LA13L+LAV70L+LA16L+LAN1P+2xNL41
<b>LAV135L</b>		2545	2545	1628	1628	1105	241.8 kg 1.13 m3 16 pcs	LAN2L+LA16L+LAV70L+LA16L+LAN1P+2xNL41
<b>LAV136L</b>		2545	3245	1628	2318	1105	268.85 kg 1.255 m3 17 pcs	LAN2L+LA23L+LAV70L+LA16L+LAN1P+2xNL41

Extra charge						
Monitor shelf x1	Monitor shelf x 2					
X	X					
X	X					
X	X					

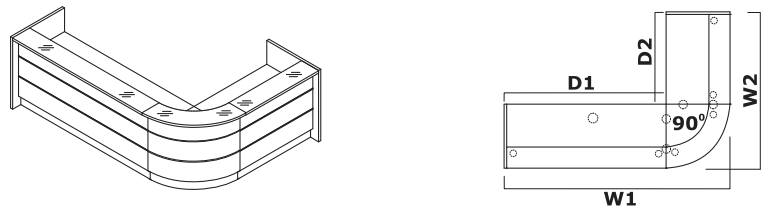

Symbol		Dimensions					kg m3 pcs	Composition elements
		W1	W2	D1	D2	H		
<b>LAV137L</b>		3245	2245	2318	1328	1105	254.95 kg 1.208 m3 17 pcs	LAN2L+LA13L+LAV70L+LA23L+LAN1P+2xNL41
<b>LAV138L</b>		3245	2545	2318	1628	1105	268.85 kg 1.255 m3 17 pcs	LAN2L+LA16L+LAV70L+LA23L+LAN1P+2xNL41
<b>LAV139L</b>		3245	3245	2318	2318	1105	295.9 kg 1.379 m3 18 pcs	LAN2L+LA23L+LAV70L+LA23L+LAN1P+2xNL41

Extra charge						
Monitor shelf x1	Monitor shelf x 2					
X	X					
X	X					
X	X					

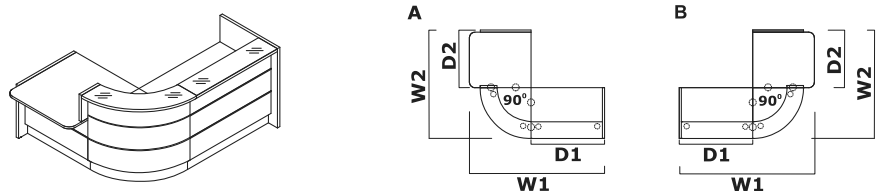

Symbol		Dimensions					kg m3 pcs	Composition elements
		W1	W2	D1	D2	H		
<b>LAV140L</b>	<b>LAV141L</b>	2442	1955	1328	1038	1105	193.3 kg 0.933 m3 17 pcs	A - LAN2L+LA13L+LAV70L+LAN3P+LAU11L+LAN5P+2xNL41 B - LAN6L+LAU11L+LAN4L+LAV70L +LA13L+LAN1P+2xNL41
<b>LAV142L</b>	<b>LAV143L</b>	2742	1955	1628	1038	1105	207.2 kg 0.98 m3 17 pcs	A - LAN2L+LA16L+LAV70L+LAN3P+LAU11L+LAN5P+2xNL41 B - LAN6L+LAU11L+LAN4L+LAV70L +LA16L+LAN1P+2xNL41
<b>LAV1401L</b>	<b>LAV1411L</b>	2442	1755	1328	838	1105	186.05 kg 0.91 m3 17 pcs	A - LAN2L+LA13L+LAV70L+LAN3P+LAU18L+LAN5P+2xNL41 B - LAN6L+LAU18L+LAN4L+LAV70L+LA13L+LAN1P+2xNL41
<b>LAV1421L</b>	<b>LAV1431L</b>	2742	1755	1628	838	1105	199.95 kg 0.957 m3 17 pcs	A - LAN2L+LA16L+LAV70L+LAN3P+LAU18L+LAN5P+2xNL41 B - LAN6L+LAU18L+LAN4L+LAV70L+LA16L+LAN1P+2xNL41

Extra charge						
Monitor shelf x1						
X						
X						
X						
X						



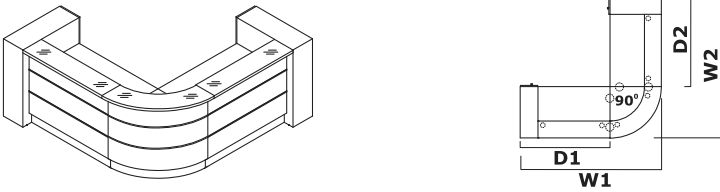

Symbol		Dimensions					kg m3 pcs	Composition elements
		W1	W2	D1	D2	H		
<b>LAV146L</b>		2525	2525	1608	1608	1105	266.6 kg 1.684 m3 18 pcs	LAD10+LAL10+LA13L+LAV70L+LA13L+LAP10+LAD10+2xNL41
<b>LAV147L</b>		2525	2825	1608	1908	1105	280.5 kg 1.731 m3 18 pcs	LAD10+LAL10+LA16L+LAV70L+LA13L+LAP10+LAD10+2xNL41
<b>LAV148L</b>		2525	3525	1608	2608	1105	307.55 kg 1.855 m3 19 pcs	LAD10+LAL10+LA23L+LAV70L+LA13L+LAP10+LAD10+2xNL41
<b>LAV149L</b>		2825	2525	1908	1608	1105	280.5 kg 1.731 m3 18 pcs	LAD10+LAL10+LA13L+LAV70L+LA16L+LAP10+LAD10+2xNL41
<b>LAV150L</b>		2825	2825	1908	1908	1105	294.4 kg 1.778 m3 18 pcs	LAD10+LAL10+LA16L+LAV70L+LA16L+LAP10+LAD10+2xNL41
<b>LAV151L</b>		2825	3525	1908	2608	1105	321.45 kg 1.902 m3 19 pcs	LAD10+LAL10+LA23L+LAV70L+LA16L+LAP10+LAD10+2xNL41

Extra charge					
Monitor shelf x1	Monitor shelf x 2				
X	X				
X	X				
X	X				
X	X				
X	X				
X	X				

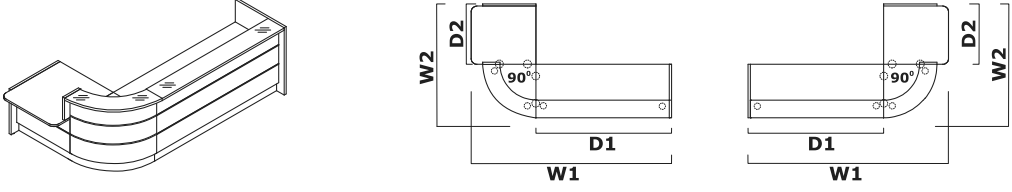

Symbol			Dimensions					kg m3 pcs	Composition elements
A	B		W1	W2	D1	D2	H		
<b>LAV144L</b>	<b>LAV145L</b>		3442	1955	2318	1038	1105	234.25 kg 1.104 m3 18 pcs	A - LAN2L+LA23L+LAV70L+LAN3P+LAU11L+LAN5P+2xNL41 B - LAN6L+LAU11L+LAN4L+LAV70L +LA23L+LAN1P+2xNL41
<b>LAV1441L</b>	<b>LAV1451L</b>		3442	1755	2318	838	1105	227 kg 1.081 m3 18 pcs	A - LAN2L+LA23L+LAV70L+LAN3P+LAU18L+LAN5P+2xNL41 B - LAN6L+LAU18L+LAN4L+LAV70L+LA23L+LAN1P+2xNL41

Extra charge					
Monitor shelf x1					
X					
X					

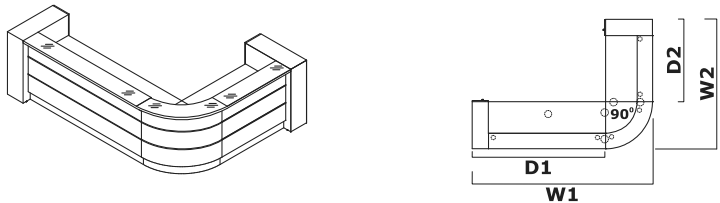

Symbol	Dimensions	kg m3 pcs	Composition elements	
				W1
<b>LAV152L</b>	3525 2525 2608 1608 1105	307.55 kg 1.855 m3 19 pcs	LAD10+LAL10+LA13L+LAV70L+LA23L+LAP10+LAD10+2xNL41	
<b>LAV153L</b>	3525 2825 2608 1908 1105	321.45 kg 1.902 m3 19 pcs	LAD10+LAL10+LA16L+LAV70L+LA23L+LAP10+LAD10+2xNL41	
<b>LAV154L</b>	3525 3525 2608 2608 1105	348.5 kg 2.027 m3 20 pcs	LAD10+LAL10+LA23L+LAV70L+LA23L+LAP10+LAD10+2xNL41	

Extra charge					
Monitor shelf x1	Monitor shelf x 2				
X	X				
X	X				
X	X				

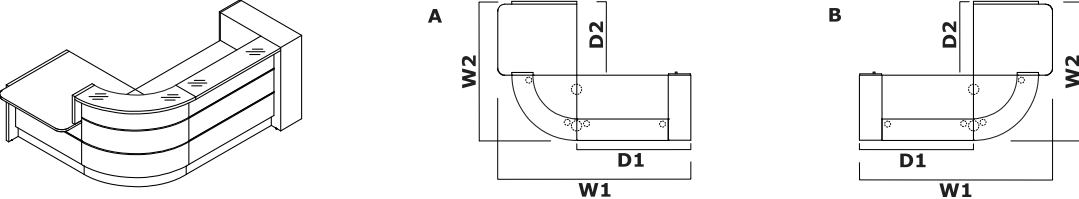

Symbol		Dimensions	kg m3 pcs	Composition elements
<b>LAV155L</b>	<b>LAV156L</b>	2722 1955 1608 1038 1105	216.8 kg 1.251 m3 17 pcs	A - LAD10+LAL10+LA13L+LAV70L+LAN3P+LAU11L+LAN5P+2xNL41 B - LAN6L+LAU11L+LAN4L+LAV70L +LA13L+LAP10+LAD10+2xNL41
<b>LAV157L</b>	<b>LAV158L</b>	3022 1955 1908 1038 1105	230.7 kg 1.299 m3 17 pcs	A - LAD10+LAL10+LA16L+LAV70L+LAN3P+LAU11L+LAN5P+2xNL41 B - LAN6L+LAU11L+LAN4L+LAV70L +LA16L+LAP10+LAD10+2xNL41
<b>LAV159L</b>	<b>LAV160L</b>	3722 1955 2608 1038 1105	257.75 kg 1.423 m3 18 pcs	A - LAD10+LAL10+LA23L+LAV70L+LAN3P+LAU11L+LAN5P+2xNL41 B - LAN6L+LAU11L+LAN4L+LAV70L +LA23L+LAP10+LAD10+2xNL41
<b>LAV1551L</b>	<b>LAV1561L</b>	2722 1755 1608 838 1105	209.55 kg 1.228 m3 17 pcs	A - LAD10+LAL10+LA13L+LAV70L+LAN3P+LAU18L+LAN5P+2xNL41 B - LAN6L+LAU18L+LAN4L+LAV70L+LA13L+LAP10+LAD10+2xNL41
<b>LAV1571L</b>	<b>LAV1581L</b>	3022 1755 1908 838 1105	223.45 kg 1.275 m3 17 pcs	A - LAD10+LAL10+LA16L+LAV70L+LAN3P+LAU18L+LAN5P+2xNL41 B - LAN6L+LAU18L+LAN4L+LAV70L+LA16L+LAP10+LAD10+2xNL41
<b>LAV1591L</b>	<b>LAV1601L</b>	3722 1755 2608 838 1105	250.5 kg 1.4 m3 18 pcs	A - LAD10+LAL10+LA23L+LAV70L+LAN3P+LAU18L+LAN5P+2xNL41 B - LAN6L+LAU18L+LAN4L+LAV70L+LA23L+LAP10+LAD10+2xNL41

Extra charge					
Monitor shelf x1					
X					
X					
X					
X					
X					

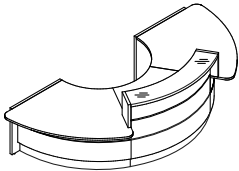
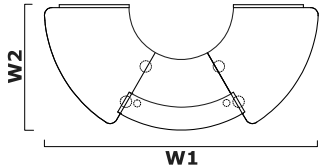
								
Symbol		Dimensions					kg m3 pcs	Composition elements
		W1	W2	D1	D2	H		
<b>LAV05L</b>		3589	1629			1105	215.65 kg 1.781 m3 17 pcs	LAN6L+2xLAV66L+LAN4L+LAV64L+LAN3P+LAN5P+2xNL41

Extra charge						
Monitor shelf x1						
X						

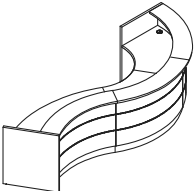
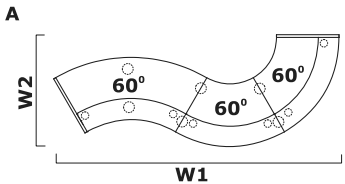
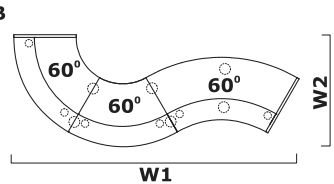
								
Symbol		Dimensions					kg m3 pcs	Composition elements
A	B	W1	W2	D1	D2	H		
<b>LAV06L</b>	<b>LAV07L</b>	4199	1629			1105	269.75 kg 2.345 m3 20 pcs	A - LAN2L+2xLAV64L+LAV62L+LAN1P+2xNL41 B - LAN2L+LAV62L+2xLAV64L+LAN1P+2xNL41

Extra charge						
Monitor shelf x1	Monitor shelf x2	Monitor shelf x3				
X	X	X				

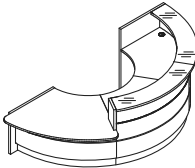
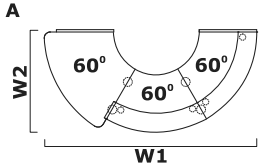
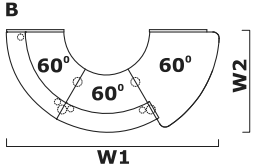
								
Symbol		Dimensions					kg m3 pcs	Composition elements
A	B	W1	W2	D1	D2	H		
<b>LAV08L</b>	<b>LAV09L</b>	3367	1629			1105	229.25 kg 2.009 m3 16 pcs	A - LAN2L+2xLAV64L+LAN3P+LAV66L+LAN5P+2xNL41 B - LAN6L+LAV66L+LAN4L+2xLAV64L+LAN1P+2xNL41

Extra charge						
Monitor shelf x1	Monitor shelf x2					
X	X					

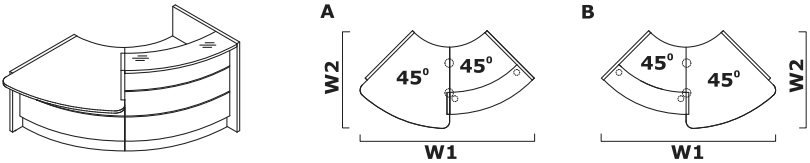

Symbol		Dimensions	kg	m3	pcs	Composition elements
A	B					
<b>LAV161L</b>	<b>LAV162L</b>	W1: 2320, W2: 1114, H: 1105	142.55	0.95	11	A - LAN2L+LAV63L+LAN3P+LAV65L +LAN5P+NL41 B - LAN6L+LAV65L+LAN4L+LAV63L +LAN1P+NL41

Extra charge						

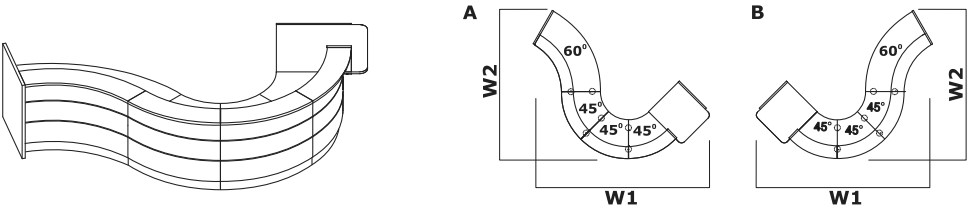

Symbol		Dimensions	kg	m3	pcs	Composition elements
A	B					
<b>LAV163L</b>	<b>LAV164L</b>	W1: 4080, W2: 3540, H: 1105	333.25	2.675	27	A - LAN6L+LAU11L+LAN4L+3xLAV63L+LAV62L+LAN1P+4xNL41 B - LAN2L+LAV62L+3xLAV63L+LAN3P+LAU11L+LAN5P+4xNL41
<b>LAV1631L</b>	<b>LAV1641L</b>	W1: 4080, W2: 3540, H: 1105	326	2.651	27	A - LAN6L+LAU18L+LAN4L +3xLAV63L+LAV62L+LAN1P+4xNL41 B - LAN2L+LAV62L+3xLAV63L+LAN3P+LAU18L+LAN5P+4xNL41

Extra charge						
Monitor shelf x1						
X						
X						

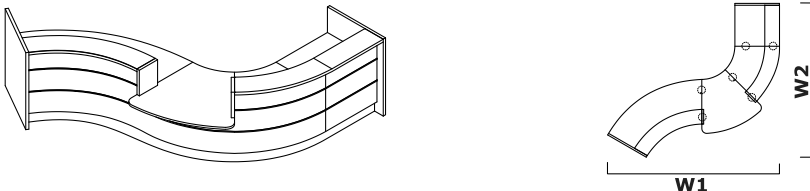

Symbol		Dimensions	kg	m3	pcs	Composition elements
A	B					
<b>LAV165L</b>		W1: 2790, W2: 3946, H: 1105	273.5	1.948	23	LAN2L+LAV62L+LAN3P+LAV65L +LAN4L+LAV63L+LA09L+LAN1P +3xNL41

Extra charge						
Monitor shelf x1						
X						













